

Mandrino porta-pinze statico - Cilindro idraulico incorporato Stationary collet-chuck - Built-in hydraulic cylinder

- Per lavorazioni in barra
For bar machining

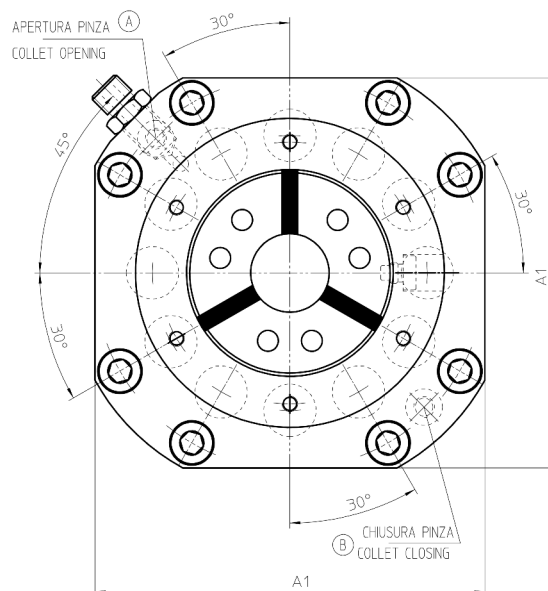
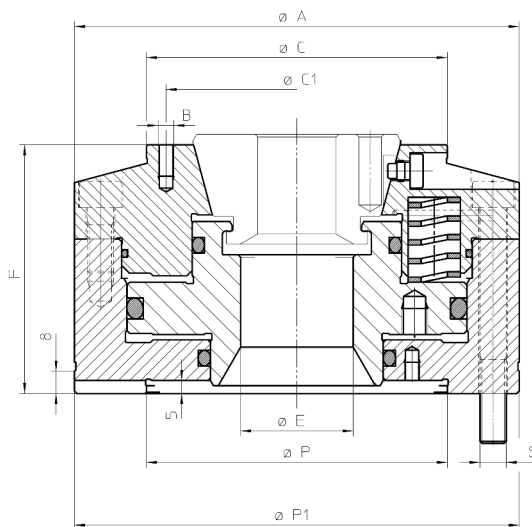
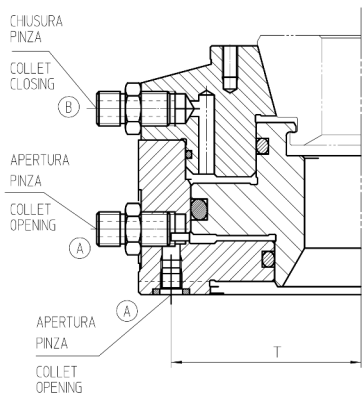
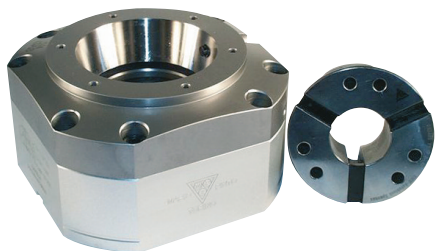

Modello MPT - MPT model	SHH 42	SHH 65
Attacco naso mac. - Machine spindle	Z115 Z170	Z140 Z200
Codice - Code	77740142	77740165
A	170	200
A1	149	174
B	6xM6	6xM6
C	115	140
C1	100	120
E	43	67
F	95	100
P H7	115	140
P1 h7	170	200
R	150	180
S	4xM10	4xM10
T	72.5	85

Pressione max Max pressure	bar	26	30
Forza assiale max a metà corsa con molle Max axial force at half stroke with springs	kN	35	42
Forza di serraggio max Max clamping force	kN	80	100

Attrezzo di ricambio Changing unit	SHH 42	SHH 65
Manuale - Manual	00196842	00196844
Pneumatico - Pneumatic	01866500	01866599

NOTA: per le pinze vedere pagine 51 e 52
Note: for collets see page 51-52

DOTAZIONE: Mandrino e viti di fissaggio
(pinze da ordinare separatamente)

EQUIPMENT: Chuck and fixing screws
(collets to be ordered separately)

Soggetto a cambiamenti tecnici - Subject to technical changes