



05415200 - LT-A D35 ER20F-20F LR H60

Tipo	LT-A DBL Portautensili angolare doppio a 90°
Attacco	CILINDRICO 35
Uscita utensile	Portapinza ER 20 F - ghiera interna
Raffreddamento	Refrigerazione esterna
Senso di rotazione	r1  r2  r3 
Velocità max [1/min]	12000
Coppia max [Nm]	25
Rapporto	1:1
H [mm]	60
H1 [mm]	28
Accessori	N.D.
Note	N.D.
Note per il montaggio	N.D.



Verificare sempre gli ingombri del portautensile in torretta

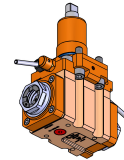
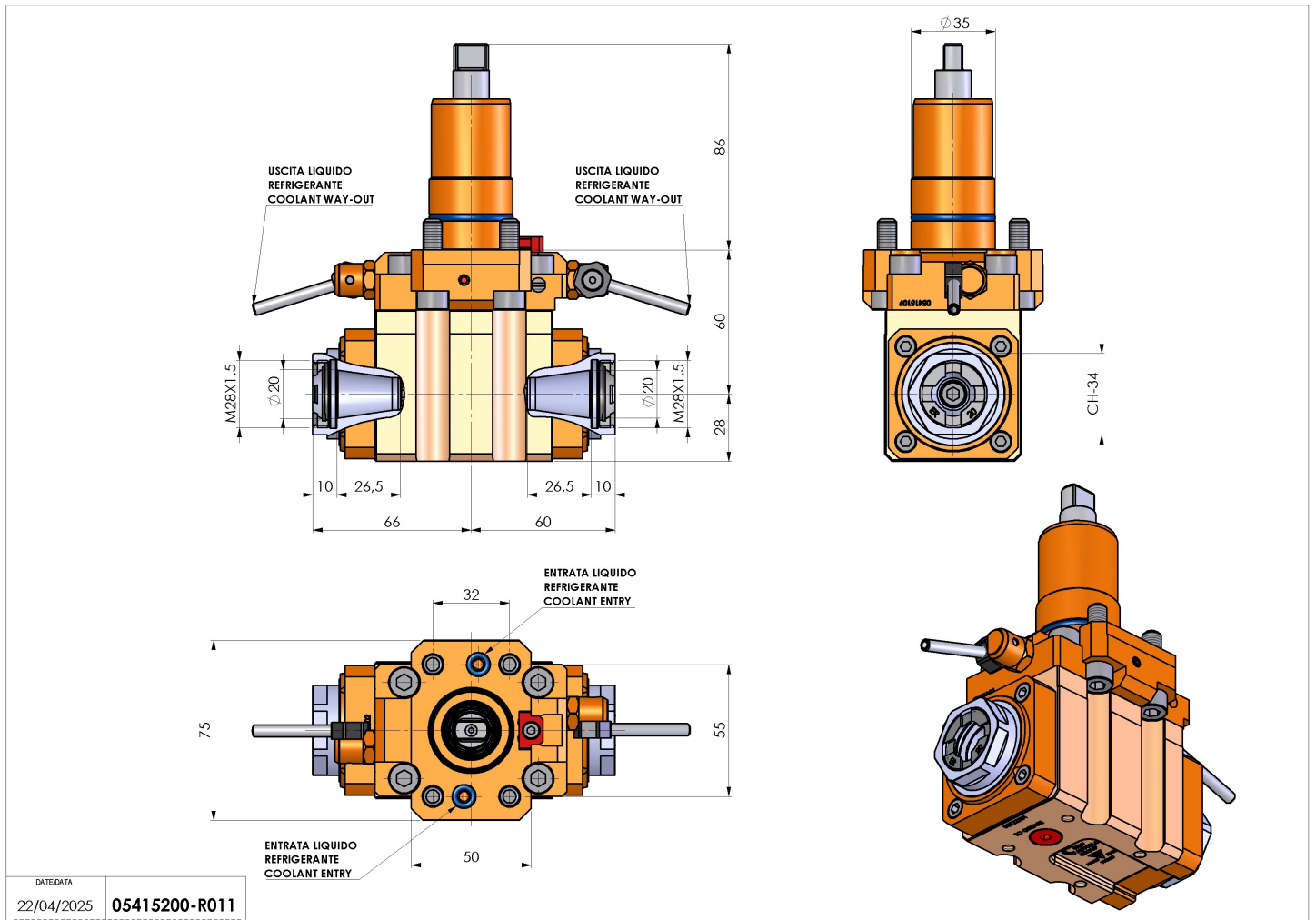

Salvo modifiche tecniche

DATE/DATE
22/04/2025 05415200-R011