



# 05231500 - LT-S2 BMT55EM KM40 OFS-75 I:70,711:1 HRF H140 MP-A242730-101

<b>Tipo</b>	LT-S2 OFS Portautensili dritto doppio offset
<b>Attacco</b>	BMT 55 EM
<b>Uscita utensile</b>	Cambio rapido KM40
<b>Raffreddamento</b>	Refrigerazione interna HRF
<b>Offset [mm]</b>	75
<b>Senso di rotazione</b>	r1  r2  r3 
<b>Velocità max [1/min]</b>	6000
<b>Coppia max [Nm]</b>	60
<b>Rapporto</b>	1:1
<b>H [mm]</b>	140
<b>Pressione max [bar]</b>	80
<b>Accessori</b>	N.D.
<b>Note</b>	N.D.
<b>Note per il montaggio</b>	N.D.



Verificare sempre gli ingombri del portautensile in torretta

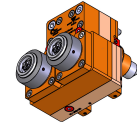
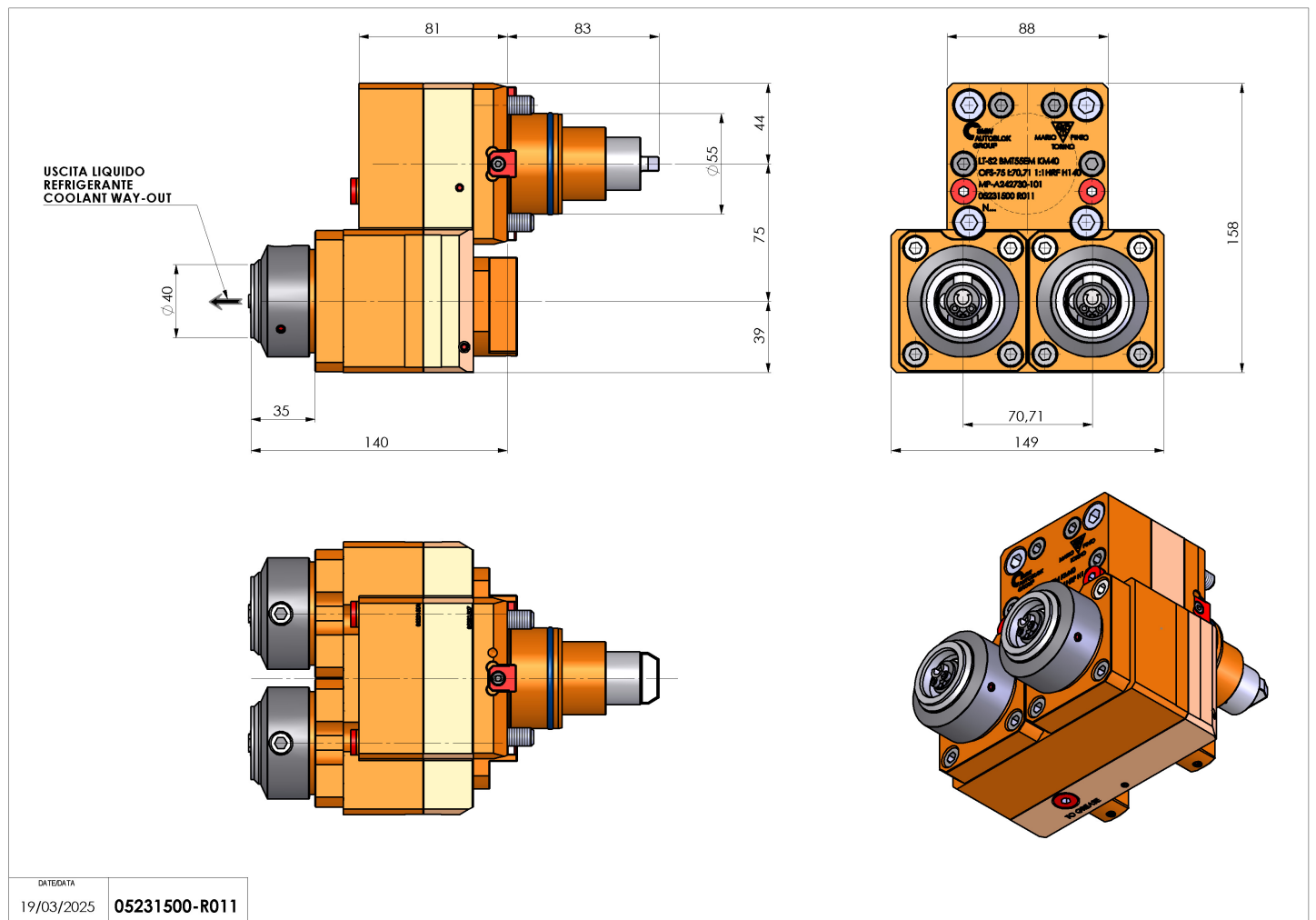

DATE/DATE	05231500-R011
19/03/2025	

Salvo modifiche tecniche