

## 05451900 - LT-A ST65 D68 C16 H104

<b>Type</b>	LT-A ST Slotting tool 90°
<b>Mounting</b>	CYLINDRICAL SHANK 68
<b>Tool output</b>	Tool diameter 16
<b>Coolant</b>	External coolant
<b>Max speed [rpm]</b>	700
<b>Max torque [Nm]</b>	17,5
<b>Ratio</b>	1:1
<b>Feed pushing [N]</b>	1000
<b>Stroke [mm]</b>	65
<b>H [mm]</b>	104
<b>Accessories</b>	N.A.
<b>Notes</b>	N.A.
<b>Mounting tips</b>	Main spindle only

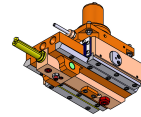

Always check live tool dimensions on the turret

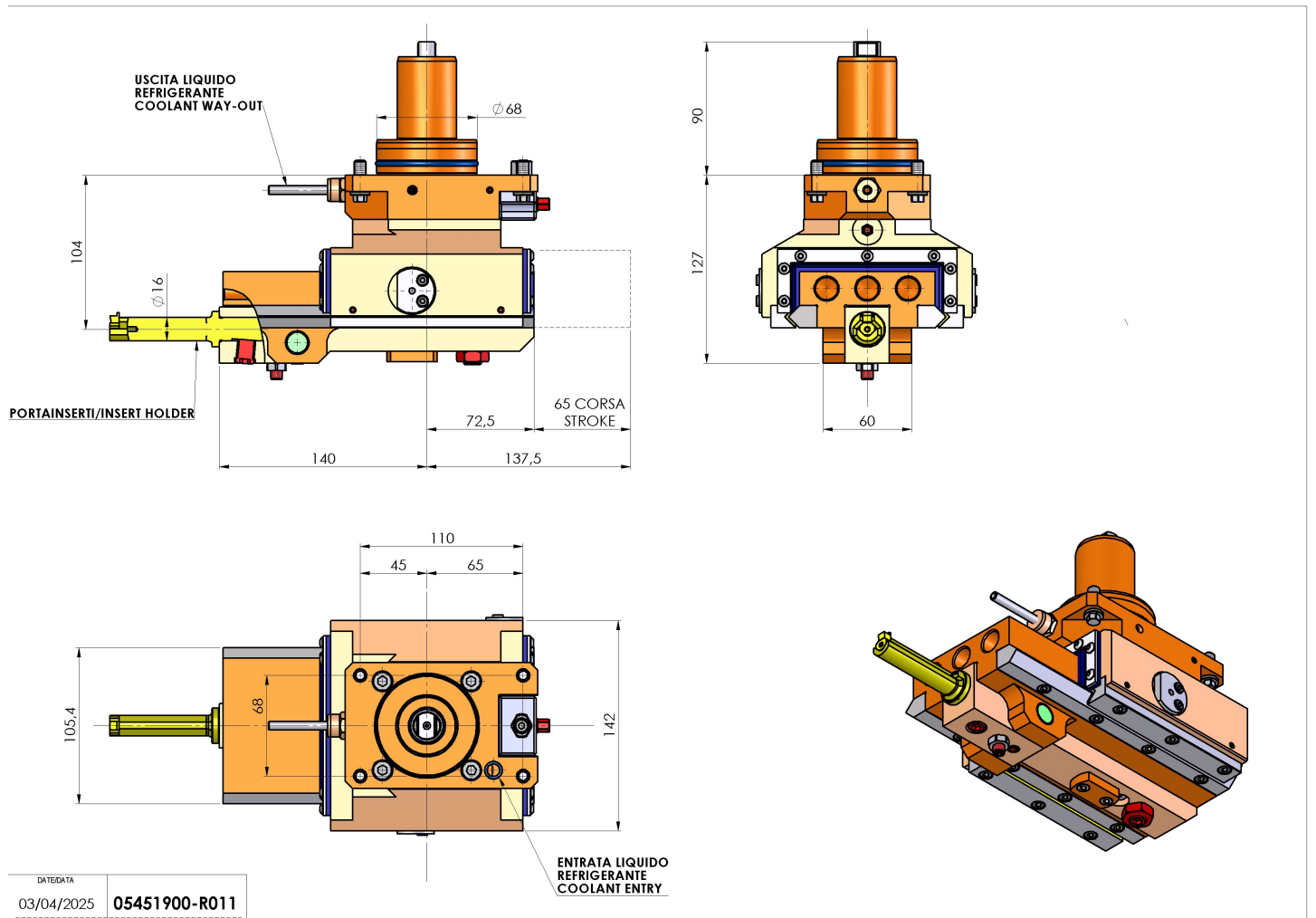

DATE/DATA  
03/04/2025 05451900-R011

Subject to technical changes