

# 05372400 - LT-A D55 WELDON25 LR HRF H70

<b>Type</b>	LT-A Tool holder angle 90°
<b>Mounting</b>	CYLINDRICAL SHANK 55
<b>Tool output</b>	Weldon 25 DIN1835B
<b>Coolant</b>	HRF Internal coolant
<b>Direction of rotation</b>	r1  r2
<b>Max speed [rpm]</b>	6000
<b>Max torque [Nm]</b>	63
<b>Ratio</b>	1:1
<b>H [mm]</b>	70
<b>H1 [mm]</b>	38
<b>Max pressure [bar]</b>	80
<b>Accessories</b>	N.A.
<b>Notes</b>	N.A.
<b>Mounting tips</b>	Main and secondary spindle

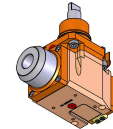

Always check live tool dimensions on the turret

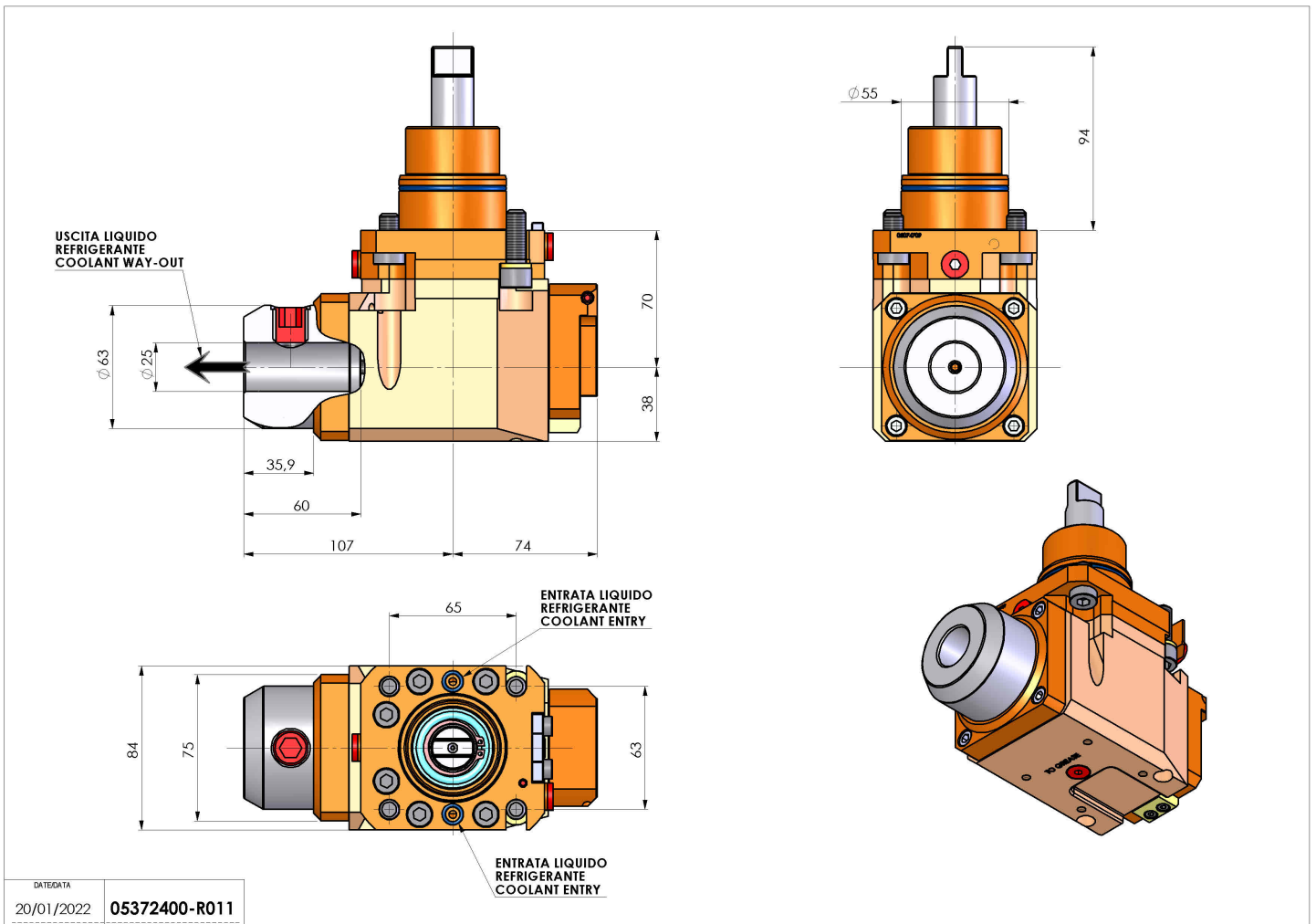

DATE/DATE: 20/01/2022 **05372400-R011**

Subject to technical changes