

05335100 - LT-A BMT85 C5 HRF H110

Type	LT-A Tool holder angle 90°
Mounting	BMT 85
Tool output	Polygonal shank C50 ISO 26623-1
Coolant	HRF Internal coolant
Direction of rotation	r1 ↻ r2 ↻
Max speed [rpm]	4000
Max torque [Nm]	180
Ratio	1:1
H [mm]	110
H1 [mm]	53
Max pressure [bar]	80
Accessories	N.A.
Notes	N.A.
Mounting tips	N.A.

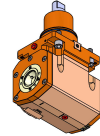

Always check live tool dimensions on the turret

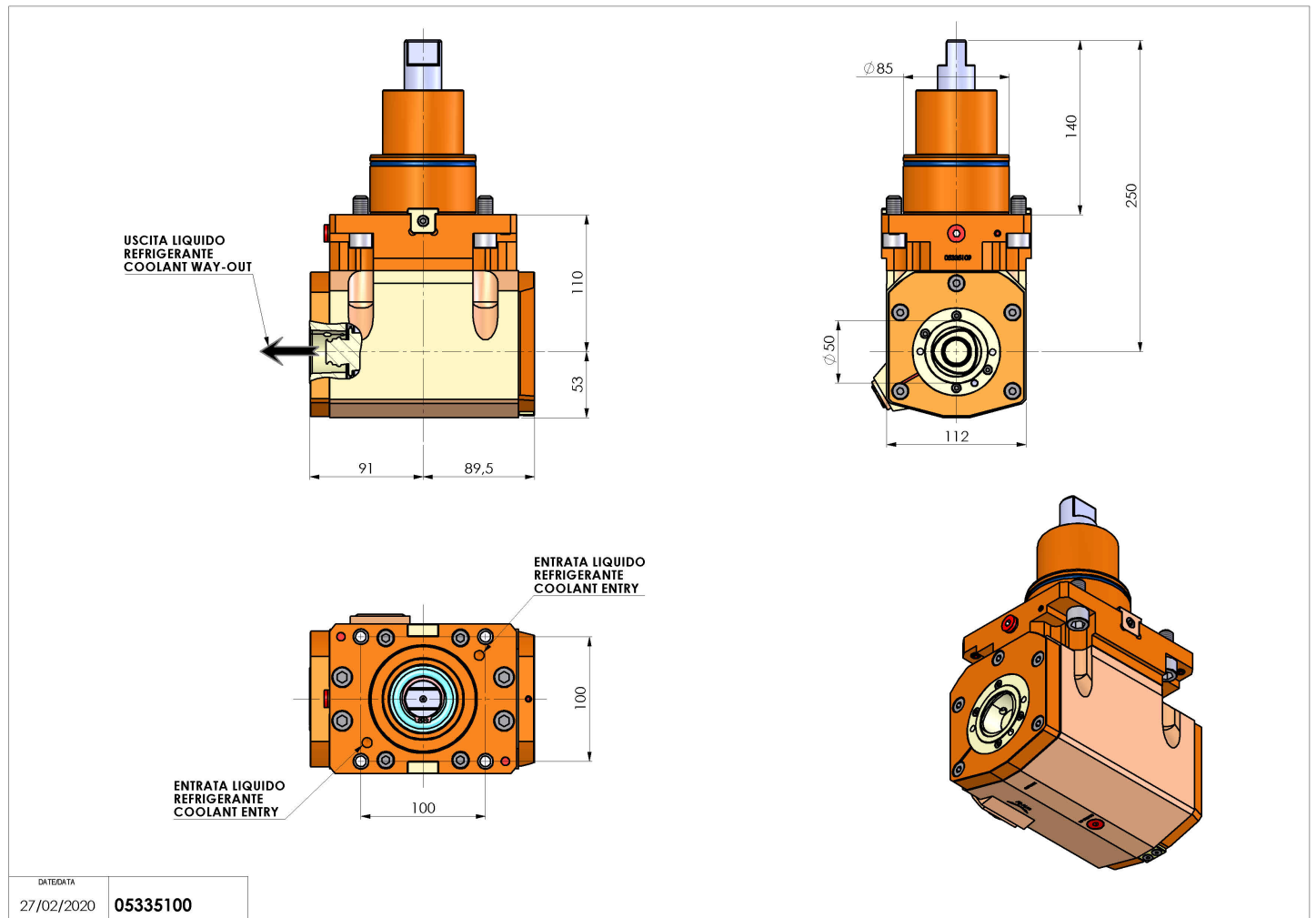

DATE/DATE	05335100
27/02/2020	

Subject to technical changes