

05182500 - LT-S VDI30 ER25 H102 DIN5482

| | |
|------------------------------|------------------------------|
| Type | LT-S Tool holder straight |
| Mounting | VDI 30 |
| Tool output | Collet nut ER 25 |
| Coolant | External coolant |
| Direction of rotation | r1 r2 |
| Max speed [rpm] | 6000 |
| Max torque [Nm] | 40 |
| Ratio | 1:1 |
| H [mm] | 102,5 |
| Accessories | |
| Notes | N.A. |
| Mounting tips | N.A. |

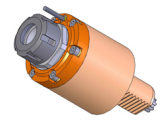

ATTENTION: CHECK THE ORIENTATION OF THE VDI TEETH

Always check live tool dimensions on the turret

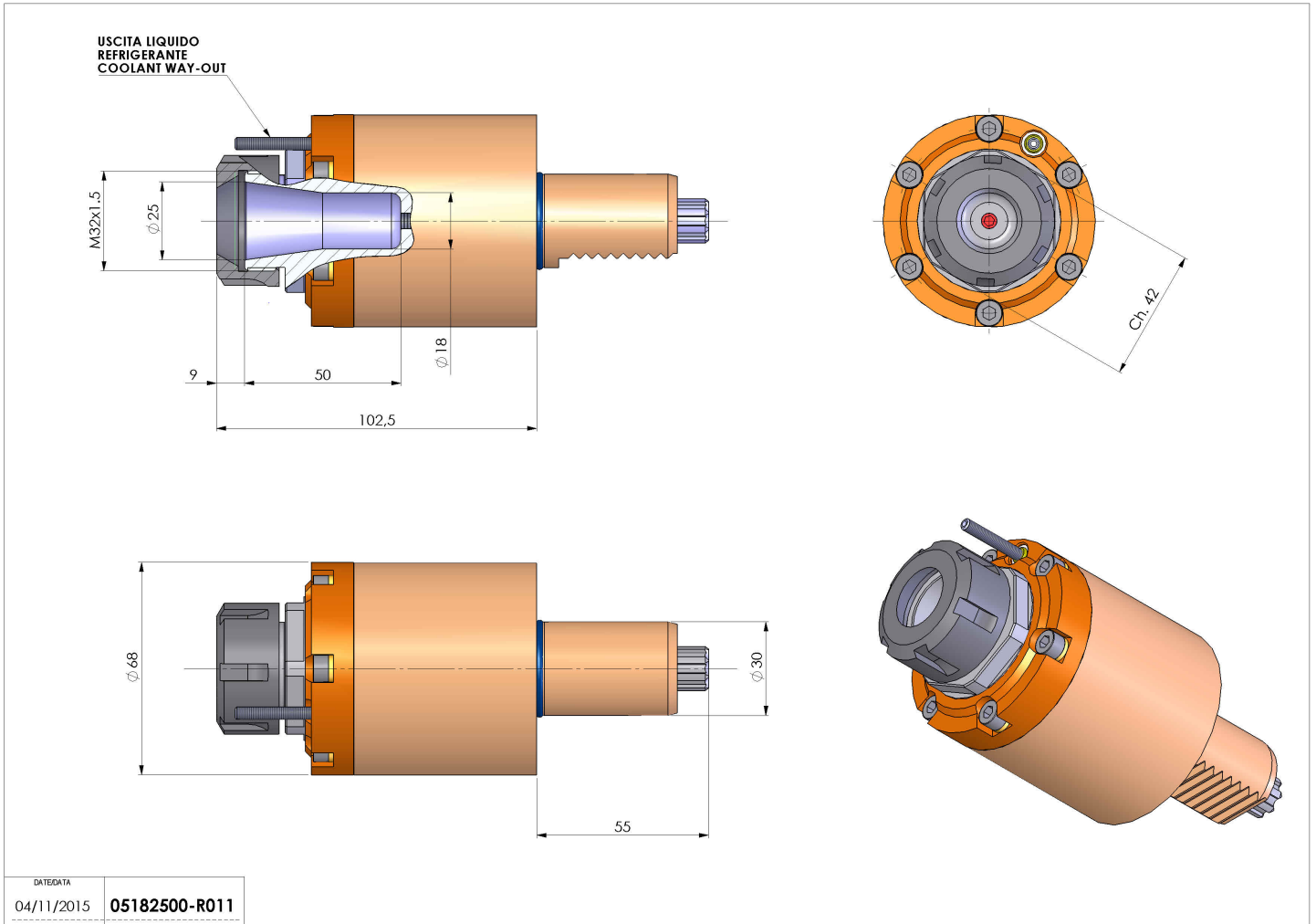

Subject to technical changes